



K+S Group

MDEC 2011, Toronto, 4/5. October 2011

---

**Reduction of Diesel Emissions in German  
Potash and Salt Mining**

**Dr. Sönksen, K+S Aktiengesellschaft, Kassel**

K+S Group

K+S Group

**Mining conditions**

---



- **5 potash mines , 3 rock salt mines,  
about 45 Mio t/y of crude ore**
- **Predominantly room and pillar method with drill and blast**
- **Ambient temperature 25 - 52 °C (depth up to 1500 m)**
- **Inclines up to 28 %  
Tilt up to 15 %**
- **Gaseous Emissions**
  - **about 75 % from diesel engines**
  - **about 25 % from ANFO explosives**

MDEC 2011 110902 TU-S6

K+S Group / 1

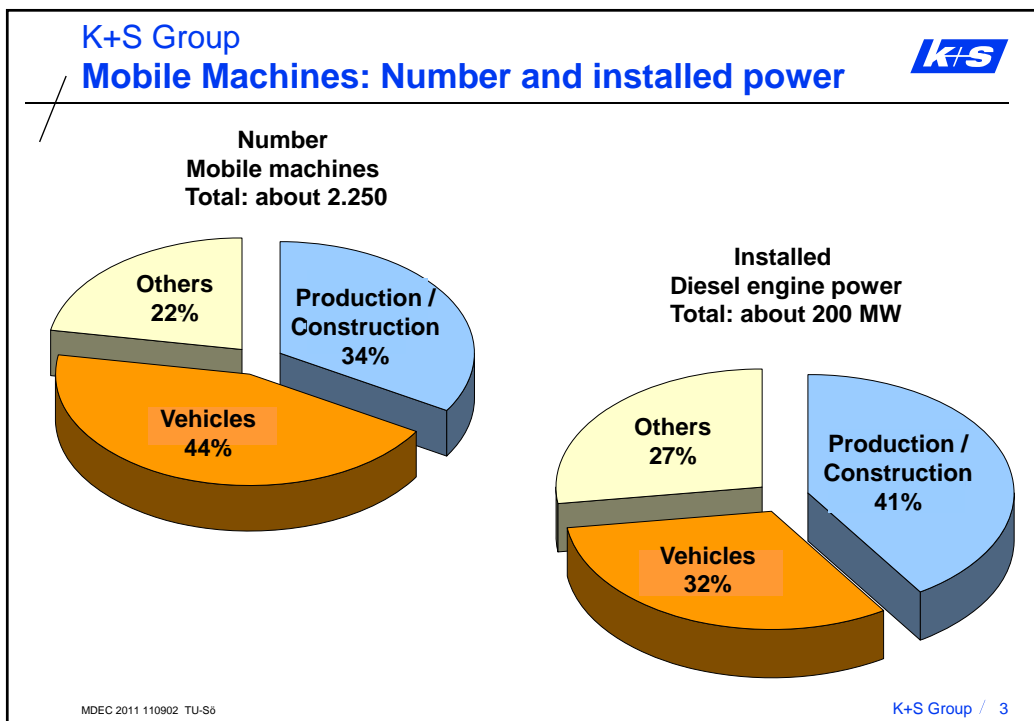
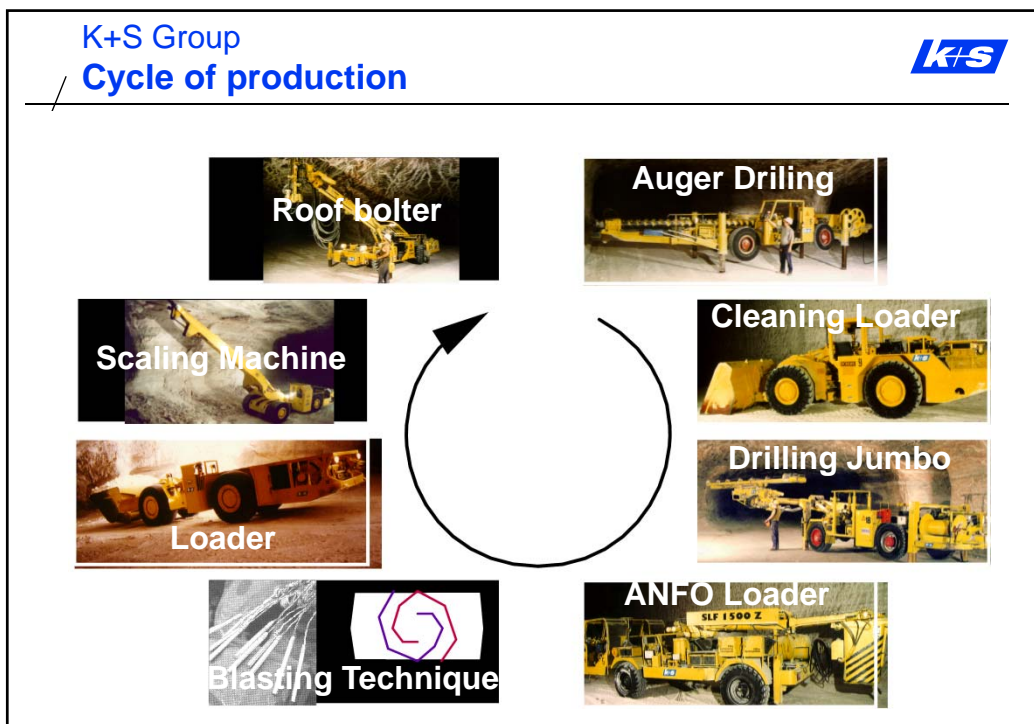

**K+S Group**  
**Threshold Limit Values in Germany**



Source	Emission	Exposure Limit
<b>Diesel engines</b>	<b>Dieselmotoremission DME</b> (elemental Carbon in fine dust)	<b>Former TRK-Value =</b> 0,1 bzw. 0.3 mg/m3
<b>Explosives</b>	<b>Carbonmonoxide CO</b>	<b>TLV = 30 ppm</b>
	<b>Carbondioxide CO<sub>2</sub></b>	<b>TLV = 5.000 ppm</b>
<b>Natural Gases</b>	<b>Nitrogenmonoxide NO</b>	<b>Former MAK-Value = 25 ppm</b>
	<b>Nitrogendioxide NO<sub>2</sub></b>	<b>Former MAK-Value = 5 ppm</b>

MDEC 2011 110902 TU-S6 K+S Group / 4

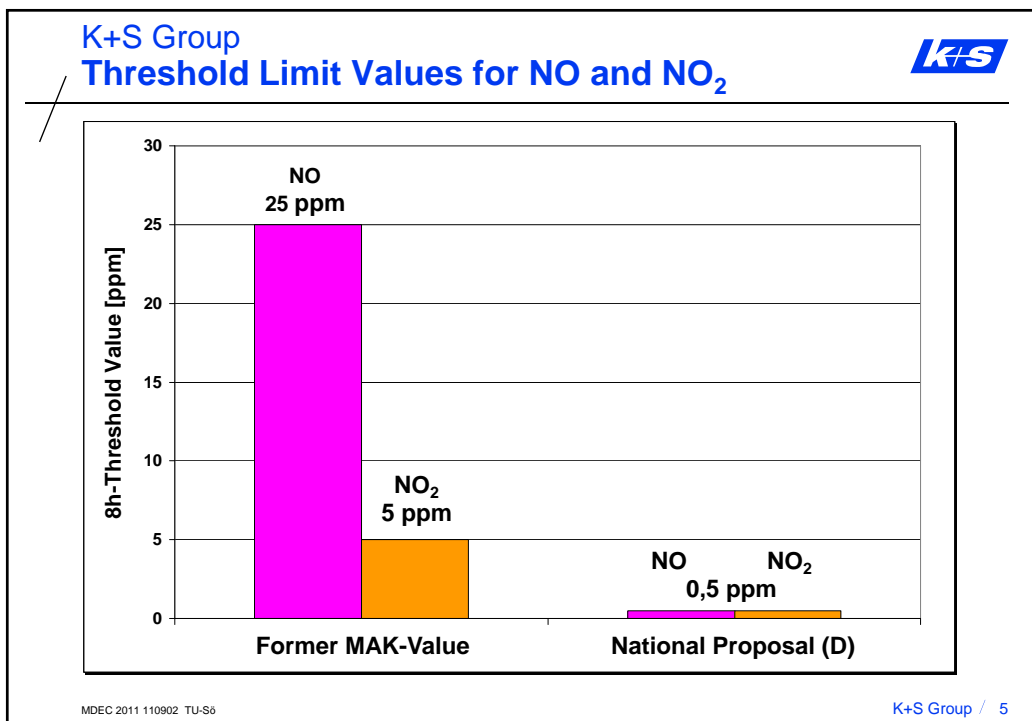

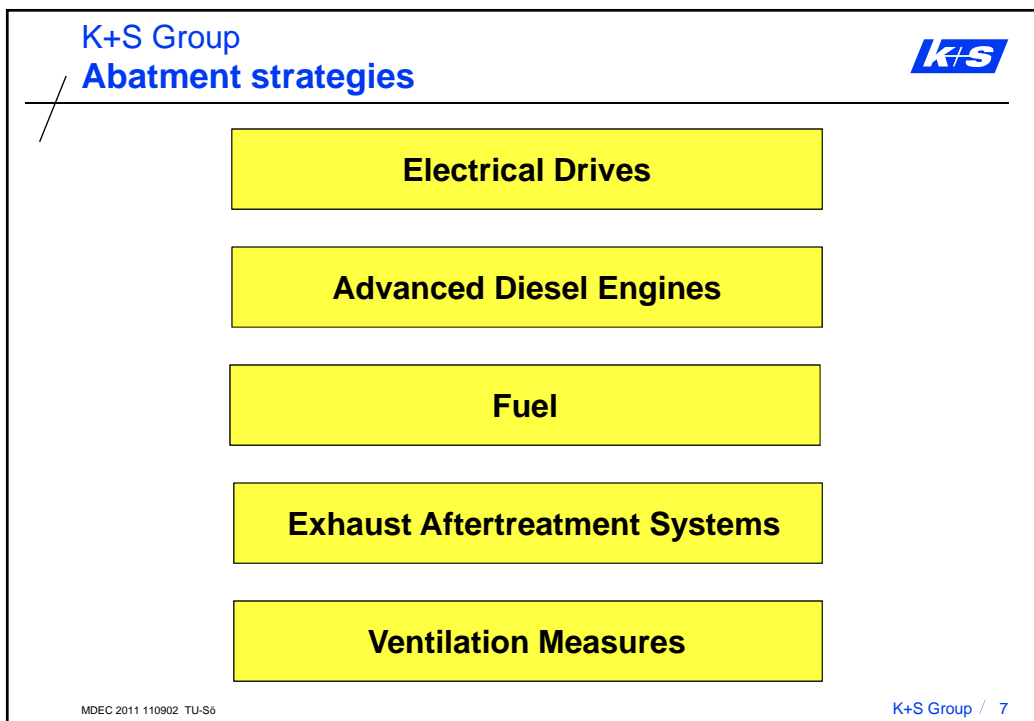
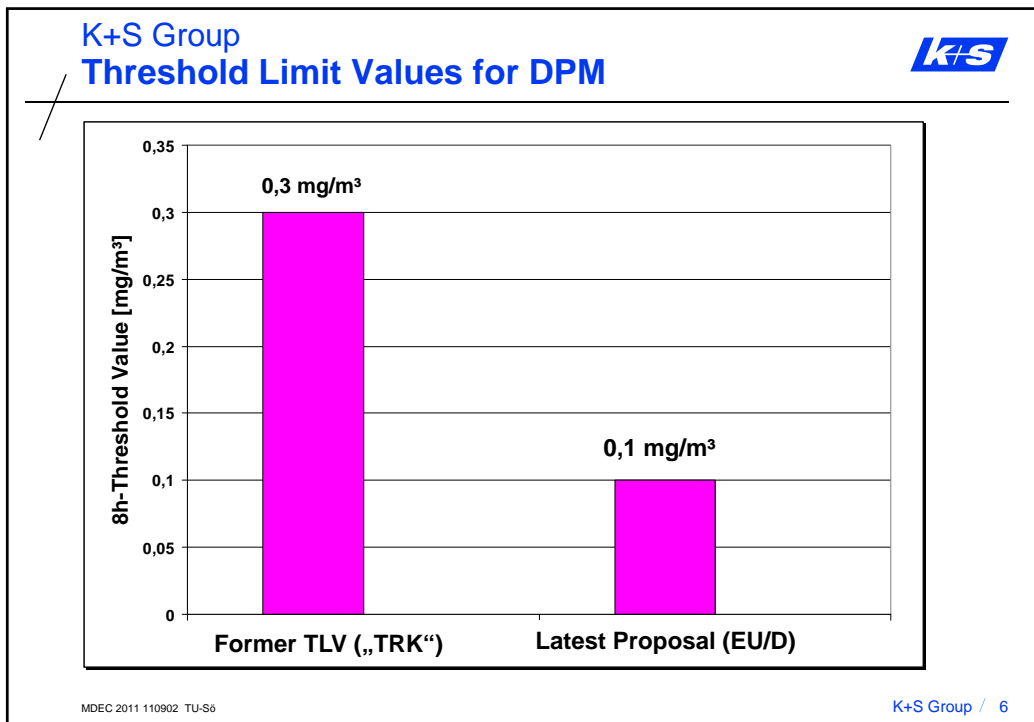

K+S Group 

**Emission reduction of Diesel engines**

---

- **Advanced Engine Technologies**
  - OnRoad: currently EURO 5
  - Off-Road Mobile Machines: currently Step III B / Tier IV i
  
- **Exhaust-After-Treatment Systems**  
(retrofit by customer or integrated by the engine manufacturer)
  - **DPF = Diesel-Particulate-Filter-Systems**  
⇒ **Regeneration! (FBC, CRT, HCpower, Burner)**
  
  - **SCR = Selective Catalytic Reduction of Nitrogenoxides**  
⇒ **AdBlue**
  
  - **SCRT = Combination of SCR and DPF**

MDEC 2011 110902 TU-S6 K+S Group / 8

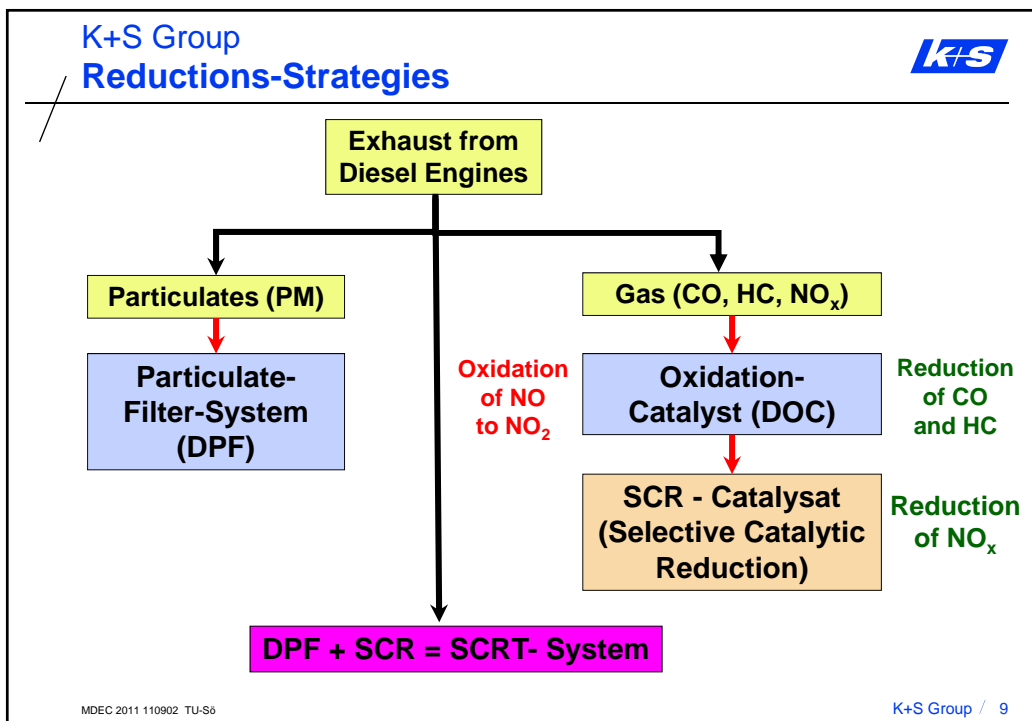

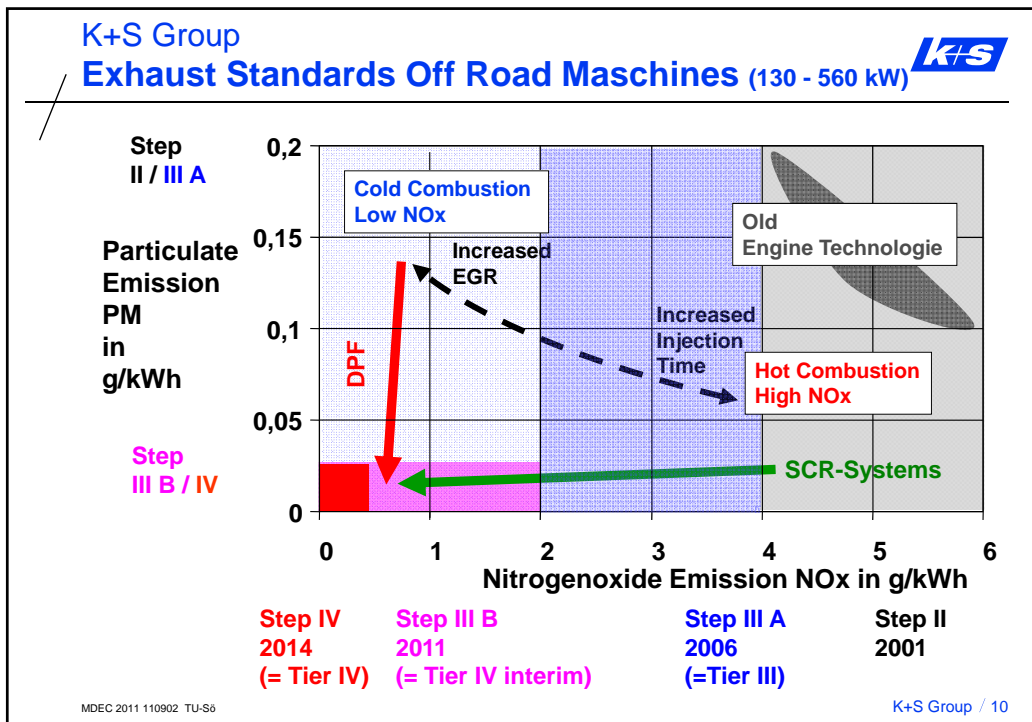

**K+S Group**  
**Particulate Filter Systems**

	Filter Element	Regeneration
• Mann + Hummel	Sintered Metal uncoated	Additive Satacan 3 (+ electrical heating) (Exhaust temperature > 300°C)
• Johnson Matthey	Silicone Carbide SiC „Low NO <sub>2</sub> -System“ NO <sub>2</sub> -Reduction + some NO <sub>x</sub> -Red.	NO <sub>2</sub> -Regeneration and Fuel Injection in Catalyst (Exhaust temperature > 250°C)
• Fischer I	Silicone Carbide SiC Uncoated	Additive Satacen 3 (Exhaust temperature > 350°C)
• Fischer III	Silicone Carbide SiC CDPX – Coating (Platin/Palladium)	Additive Satacen 3 (Exhaust temperature > 320°C)
• Fischer HC power	Silicion Carbide SiC Uncoated	Fuel Injection / Vaporizer (Exhaust temperature > 250°C)

MDEC 2011 110902 TU-S6

K+S Group / 11

K+S Group

Filtersystem Mann+Hummel, Sintered metal filter

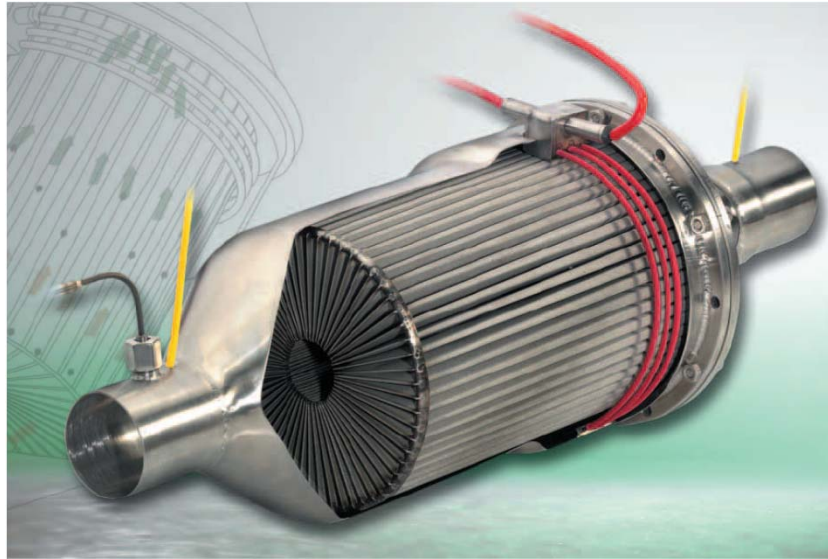

MDEC 2011 110902 TU-S6

K+S Group / 12

K+S Group

Filtersystem Mann+Hummel, Sintered metal filter



LF 12.2

DEUTZ  
F 12 L413 FW  
187 kW  
2.300 1/min

MDEC 2011 110902 TU-S6

K+S Group / 13

K+S Group

Filtersystem Mann+Hummel, Sintered metal filter



- ☺ Low Back Pressure
- ☺ High Capacity for Soot and FBC-Ash
- ☺ Robust System
- ☺ Wide range of exhaust temperatures with electrical heating
- ☹ Required installation space (in comparison to SiC-filter)

MDEC 2011 110902 TU-S6

K+S Group / 14

K+S Group

Low NO<sub>2</sub>- CRT<sup>®</sup>- System Johnson Matthey (1)

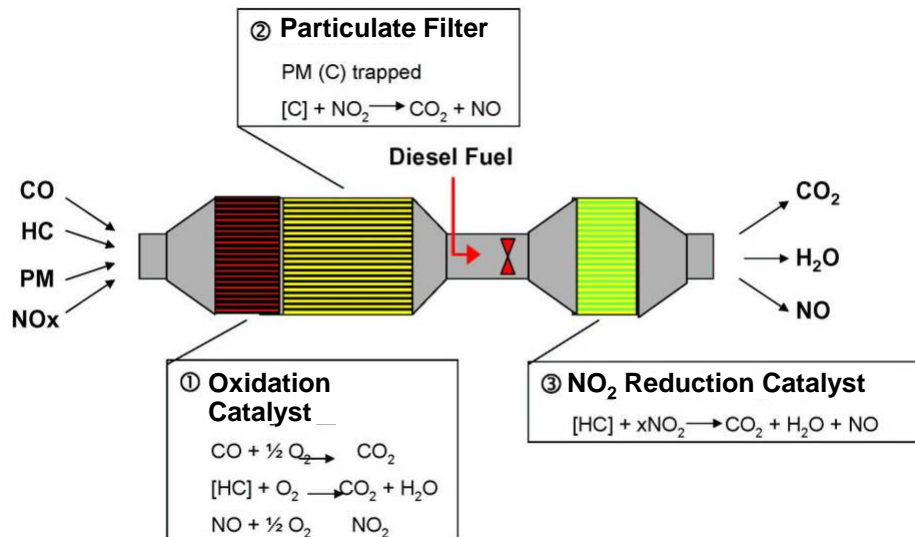

MDEC 2011 110902 TU-S6

K+S Group / 15

K+S Group  
Low NO<sub>2</sub> - CRT<sup>®</sup> - System Johnson Matthey (2)

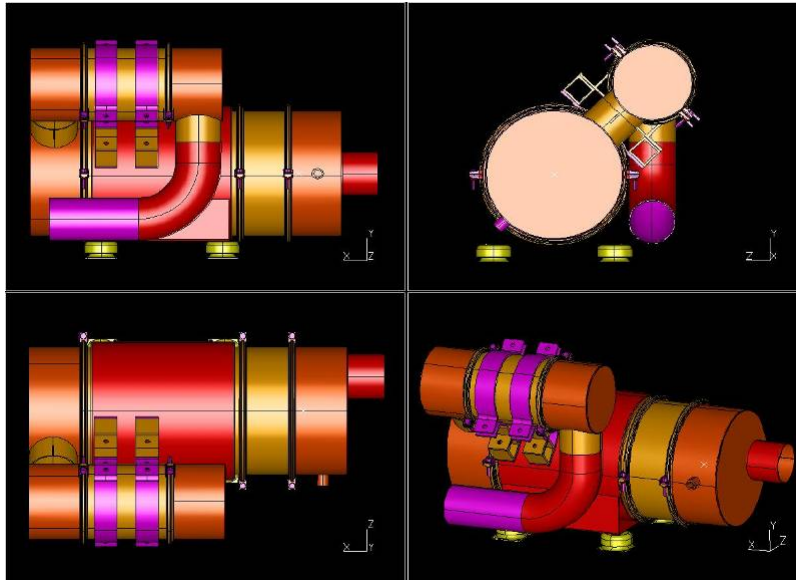

MDEC 2011 110902 TU-S6

K+S Group / 16

K+S Group  
Low NO<sub>2</sub> - CRT<sup>®</sup> - System Johnson Matthey (3)

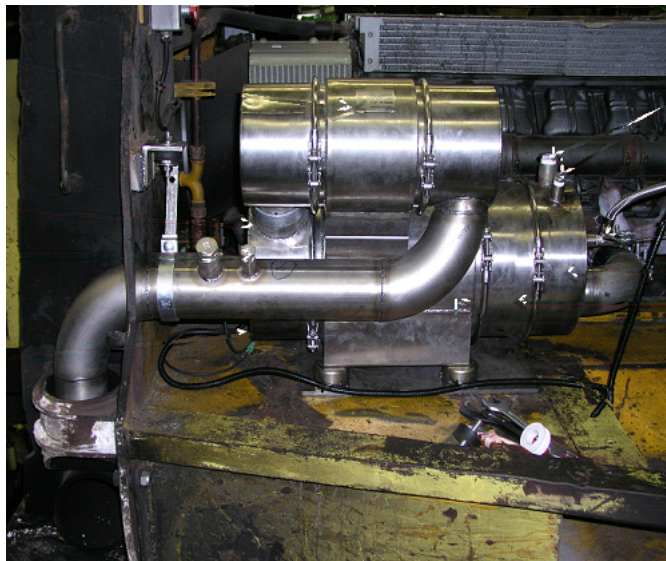

LF 12.2

F 12 L413 FW  
187 kW  
2.300 1/min

MDEC 2011 110902 TU-S6

K+S Group / 17

K+S Group

Low NO<sub>2</sub> - CRT<sup>®</sup> - System Johnson Matthey (4)



MDEC 2011 110902 TU-S6

K+S Group / 18

K+S Group

Low NO<sub>2</sub> - CRT R- System Johnson Matthey (5)



- ☺ No need for FBC or electrical heating
- ☺ Wide range of exhaust temperatures
- ☹ Complex system for air supply and fuel injection
- ☹ Required installation space
- ☹ Expensive System

MDEC 2011 110902 TU-S6

K+S Group / 19

**K+S Group**  
**Super Low Profile Loader SLP 12**



<b>Pay Load:</b>	<b>12 t</b>
<b>Total Weight:</b>	<b>50 t</b>
<b>Machine Height:</b>	<b>1,65 m</b>
<b>Bucket width:</b>	<b>4,62 m</b>

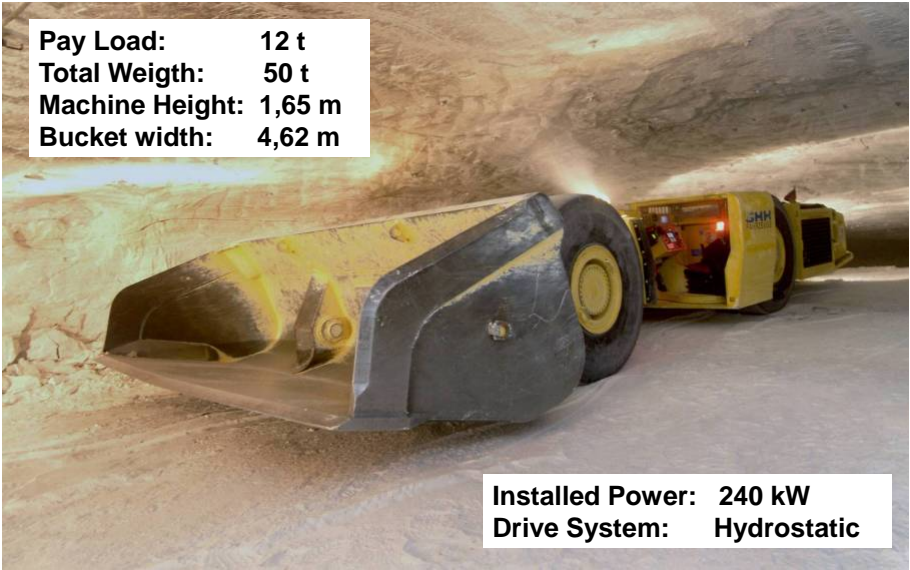

<b>Installed Power:</b>	<b>240 kW</b>
<b>Drive System:</b>	<b>Hydrostatic</b>

MDEC 2011 110902 TU-S6 K+S Group / 20

**K+S Group**  
**SLP 12 – 1st Generation**

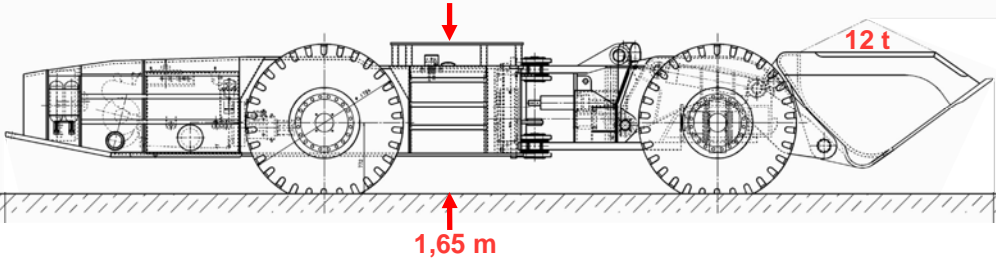
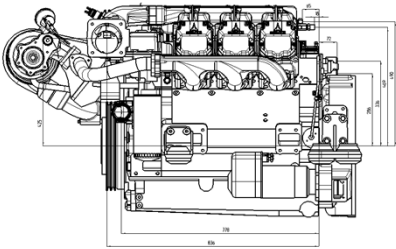
**Diesel Engine:**  
**TCD 2015 V6 - Step III A**  
**240 kW / 2000 1/min**  
 +  
**Fischer-DPF with**  
**Additive-Regeneration**  
 or  
**HCpower**

MDEC 2011 110902 TU-S6 K+S Group / 21

K+S Group

**Fischer DPF with FBC-Regeneration**



- ☺ Low installation space required
- ☺ Simple Dosing System
  
- ☹ Negative impact of FBC on fuel oxidation stability under high injection pressure
  
- ☹ Coking of the Injection Nozzles of the diesel engine after ~ 500 hours due to high back pressure (Step IIIA Engines with high soot emission!)
  
- ☹ Low operation time of the filter elements of ~ 1000 hours with need for frequent external cleaning procedures

MDEC 2011 110902 TU-S6

K+S Group / 22

K+S Group

**Fischer DPF with Fuel Regeneration HC power (1)**

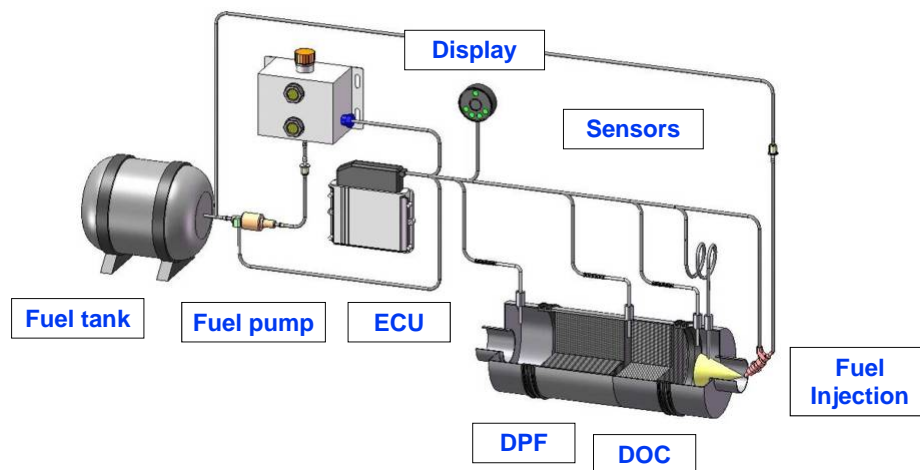

MDEC 2011 110902 TU-S6

K+S Group / 23

**K+S Group**  
**SLP 12 with Fischer DPF HC power**





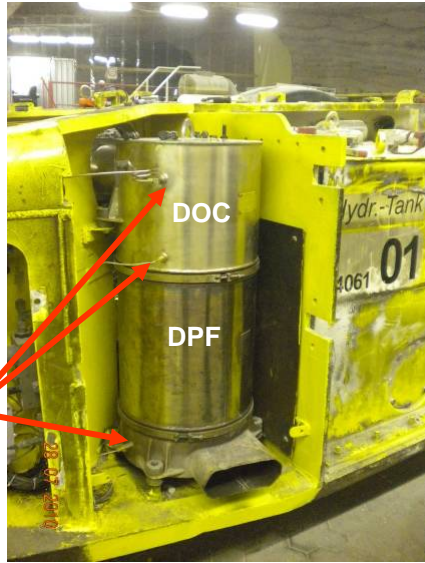

**Water cooled  
Fuel Injection  
Nozzle**

**Temperature  
Sensors**

MDEC 2011 110902 TU-S6 K+S Group / 24

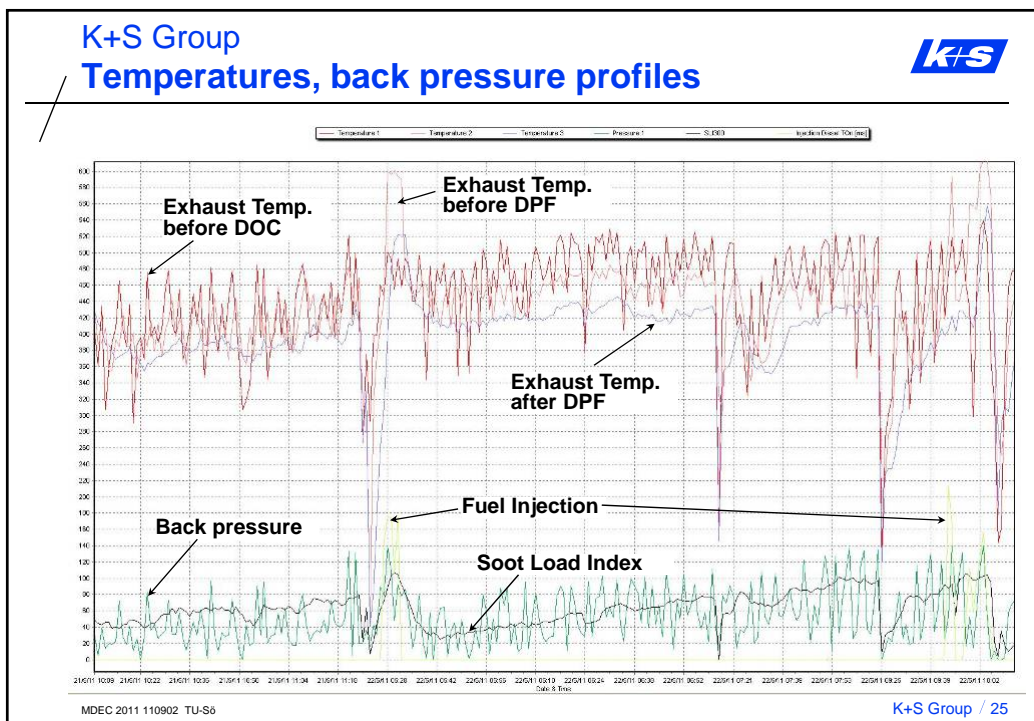

K+S Group

LF 7.4B with Fischer DPF HC power (1)



Diesel Engine:  
TCD 2013 L6 - Step III A  
181 kW / 2000 1/min

Fischer-DPF HCpower Vapo II

MDEC 2011 110902 TU-S6

K+S Group / 26

K+S Group

LF 7.4B with Fischer DPF HC power (2)

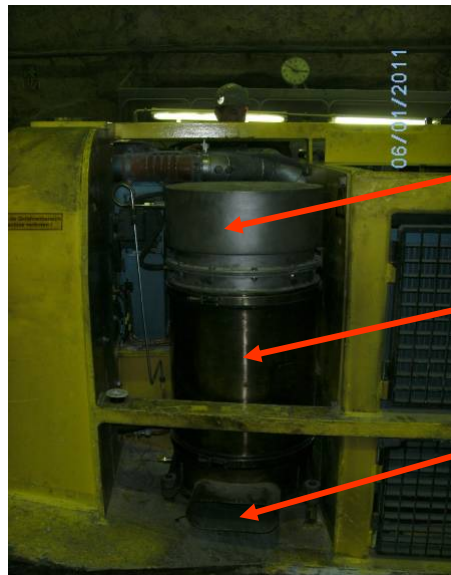

Exhaust Intake Chamber with Pre-Catalyst

SiC-Element

Exhaust Outlet

MDEC 2011 110902 TU-S6

K+S Group / 27

K+S Group  
LF 7.4B with Fischer DPF HC power (3)

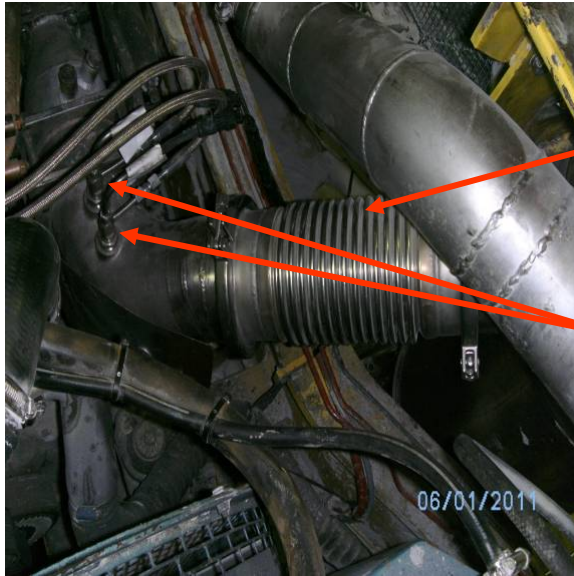

Compensator

Fuel Vaporizer

MDEC 2011 110902 TU-S6

K+S Group / 28

K+S Group  
LF 7.4B with Fischer DPF HC power (4)

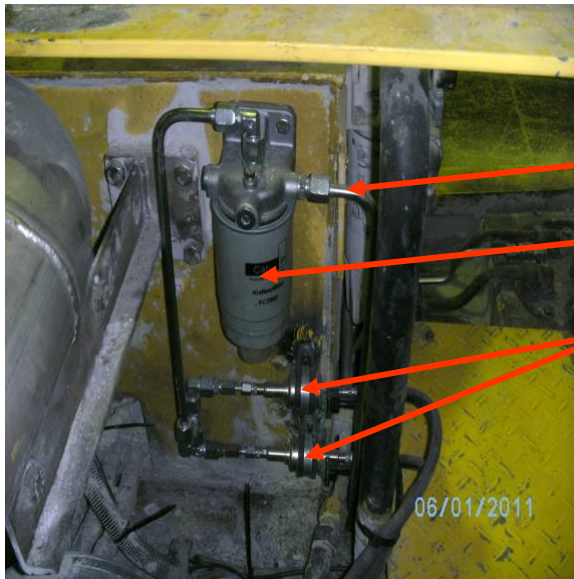

Fuel Supply



Fuel filter

Fuel Pumps

MDEC 2011 110902 TU-S6

K+S Group / 29

K+S Group  
LF 7.4B with Fischer DPF HC power (5)

Engine ECU

DPF ECU

Electrical Supply

MDEC 2011 110902 TU-S6

K+S Group / 30

K+S Group  
Fischer DPF with Fuel Regeneration HC power



- ☺ No need for FBC or electrical heating
- ☺ Wide range of exhaust temperatures
- ☺ Low back pressure due to active regeneration
- ☺ High operation time of filter elements  
( > 2500 hours on first system !)
- ☹ Complex System for fuel injection  
(with water cooled nozzles for engines > 200 kW)
- ☹ Individuell Optimization of Mapping / Catalyst Coating  
according to load profile to prevent HC slippage
- ☹ Small increase of NO<sub>2</sub>  
(up to 1,3 higher rate in comparison to raw emission)

MDEC 2011 110902 TU-S6

K+S Group / 31

K+S Group  
SLP 14/12 – 2nd Generation

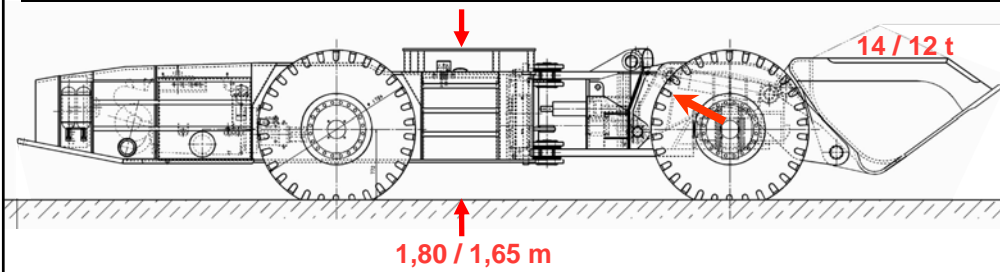

Quelle:  
DEUTZ AG

**Diesel Engine**  
TCD 7.8 L6 - Step III B  
245 kW, 2000 1/min

+ DEUTZ-DPF with  
Fuel Burner Regeneration

MDEC 2011 110902 TU-S6

K+S Group / 32

K+S Group  
SLP 14/12 – 2. Generation

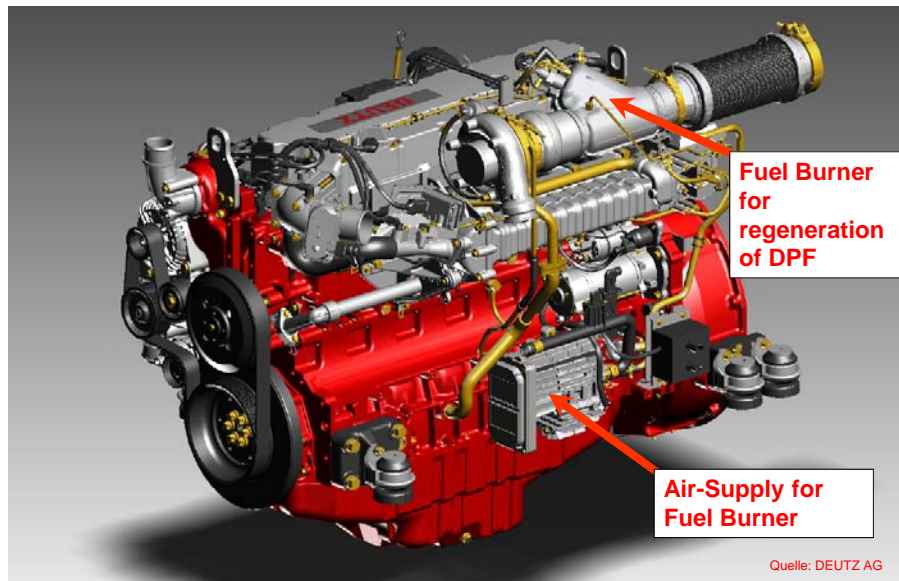

Quelle: DEUTZ AG

MDEC 2011 110902 TU-S6

K+S Group / 33

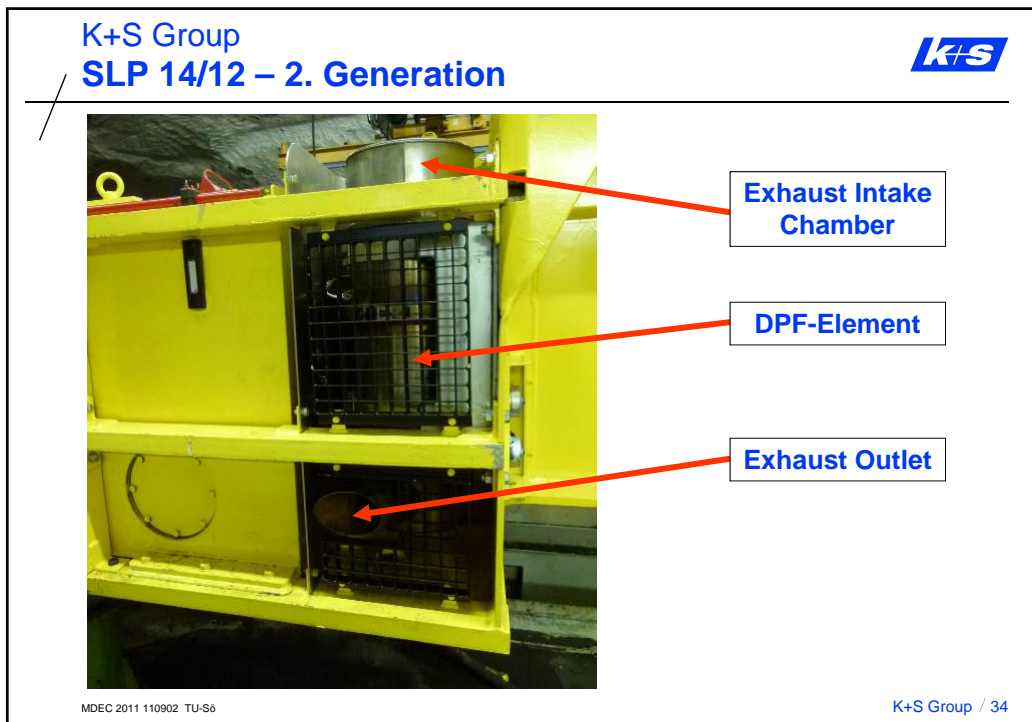

K+S Group  
DEUTZ Burner System

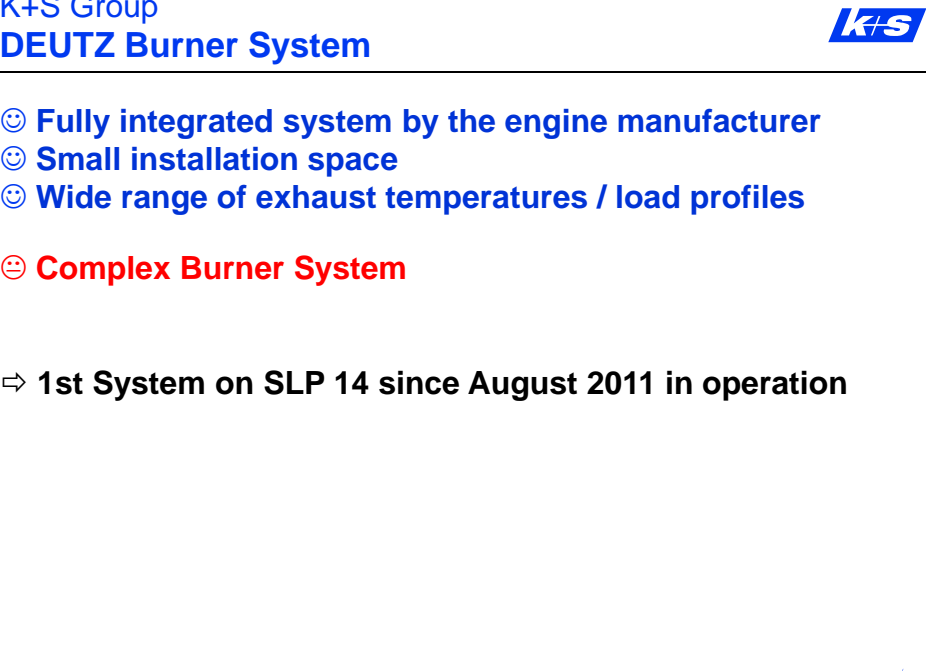

☺ Fully integrated system by the engine manufacturer

☺ Small installation space

☺ Wide range of exhaust temperatures / load profiles

☹ **Complex Burner System**

⇒ 1st System on SLP 14 since August 2011 in operation

MDEC 2011 110902 TU-S6

K+S Group / 35

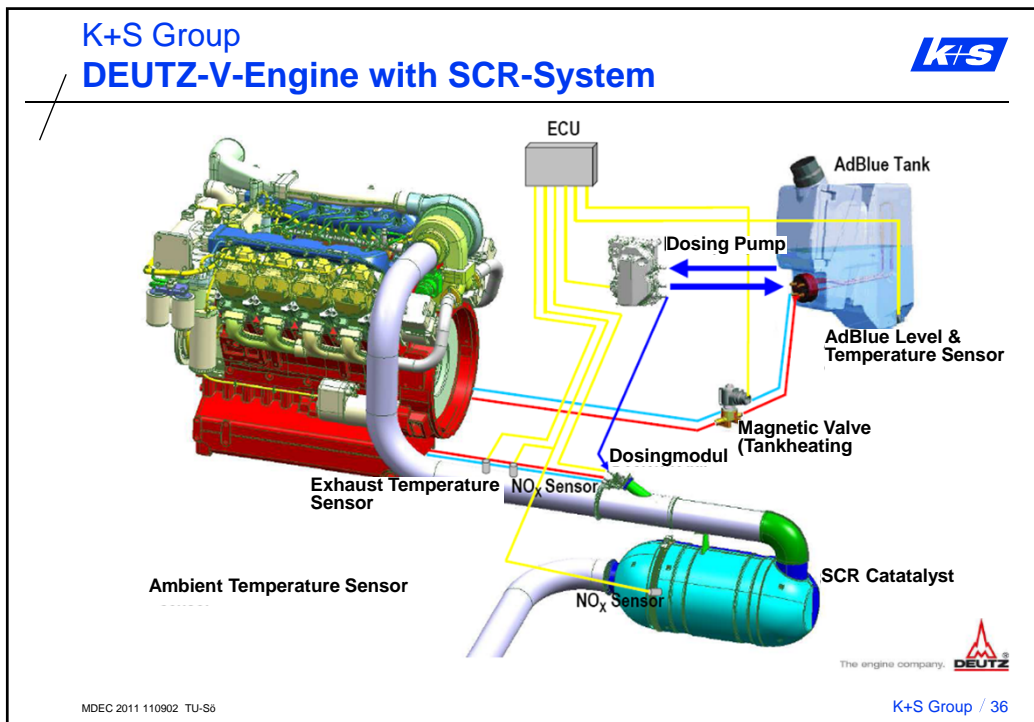

K+S Group

Road cutting machine with DEUTZ-SCR-System



MDEC 2011 110902 TU-S6

K+S Group / 38

K+S Group

DEUTZ SCR System



- ☺ Low Particulate emission due to Tier IV interim engine
- ☺ NO<sub>x</sub>-Reduction > 75 %
- ☺ Lowest minimim ventilation rate
- ☺ Operation without major problems
  
- ☹ Minimum exhaust temperature of about 240 °C for injection of AdBlue

MDEC 2011 110902 TU-S6

K+S Group / 39

K+S Group  
Loader LF 20 D



BF 8M1015  
320 kW  
2000 1/min

MDEC 2011 110902 TU-S6

K+S Group / 40

K+S Group  
Johnson Matthey SCRT-System LF 20 D

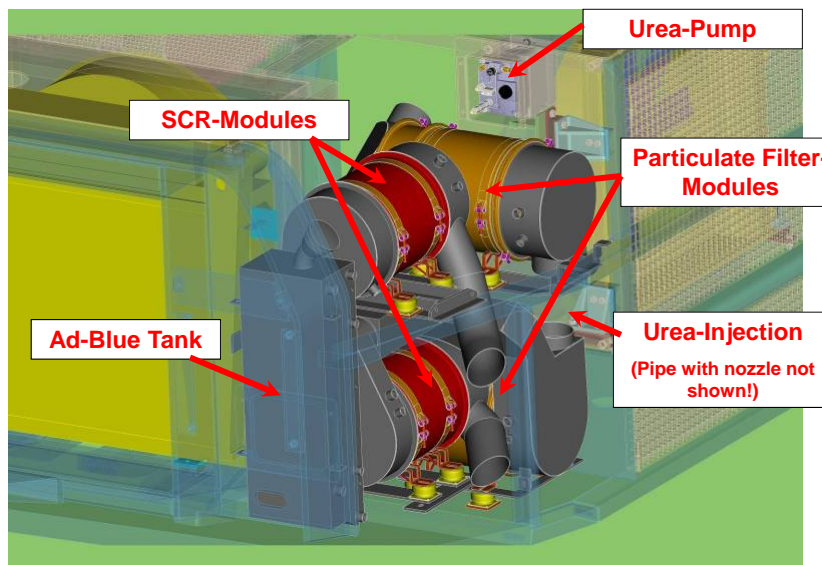

MDEC 2011 110902 TU-S6

K+S Group / 41

K+S Group  
Johnson Matthey SCRT-System LF 20 D

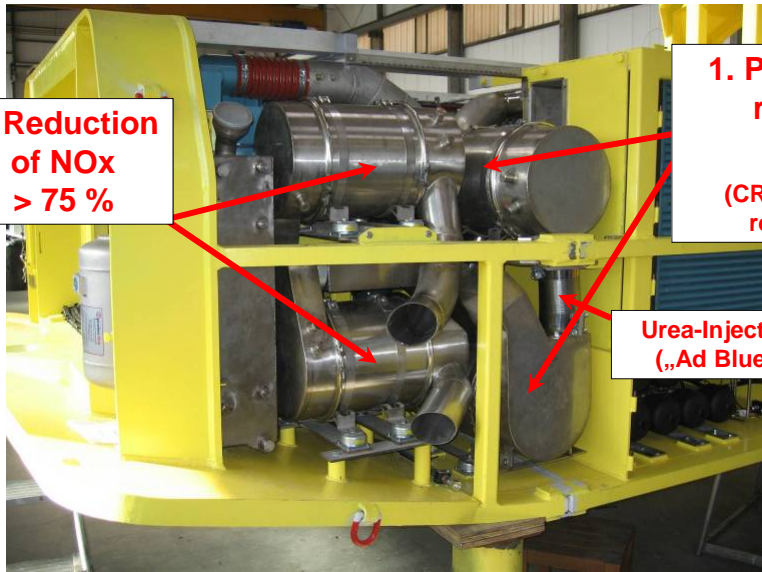

**1. Particulate reduction > 95 %**  
(CRT effect for regeneration)

**2. Reduction of NO<sub>x</sub> > 75 %**

**Urea-Injection („Ad Blue“)**

MDEC 2011 110902 TU-S6

K+S Group / 42

K+S Group  
Johnson Matthey SCRT-System LF 20 D

- ☺ **Particulate reduction > 95 %**
- ☺ **NO<sub>x</sub>-Reduction > 75 %**
- ☹ **Complex System with high installation space required**
- ☹ **Redesign of the Electrical and Air supply system through the machine manufacturer to get a robust system suitable for mining conditions**
- ☹ **Minimum exhaust temperature of about 240 °C for injection of AdBlue**
- ☹ **System is sensitive to high backpressure and soot overload**
  - ⇒ **Optimization of the backpressure monitoring system**
  - Special skilled maintenance people with high quality service instructions necessary**

MDEC 2011 110902 TU-S6

K+S Group / 43

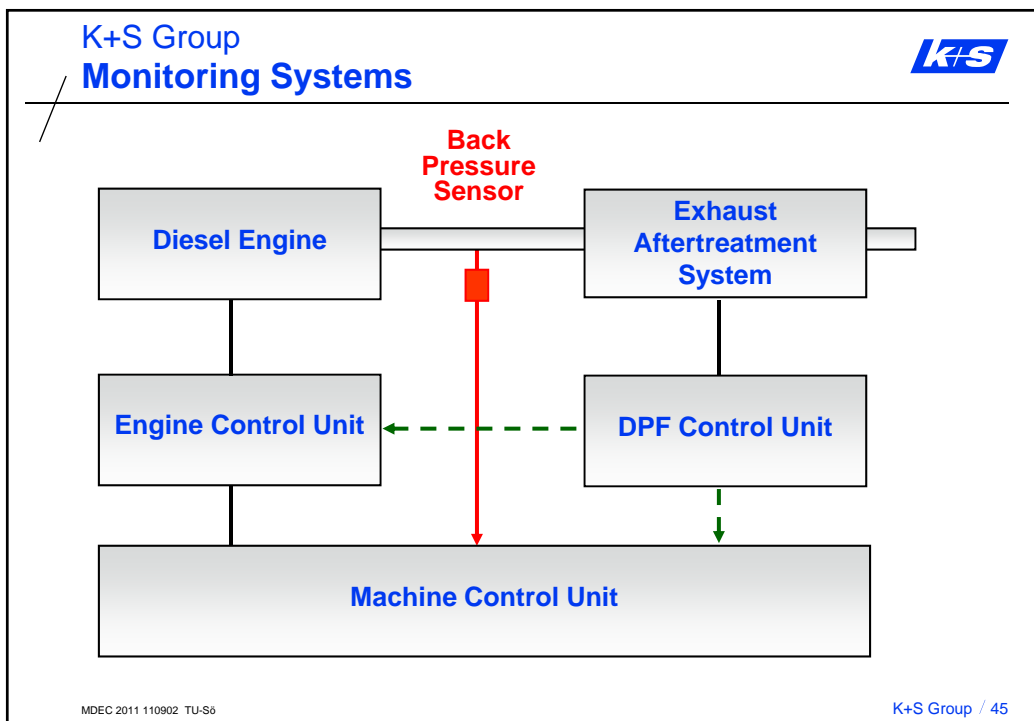
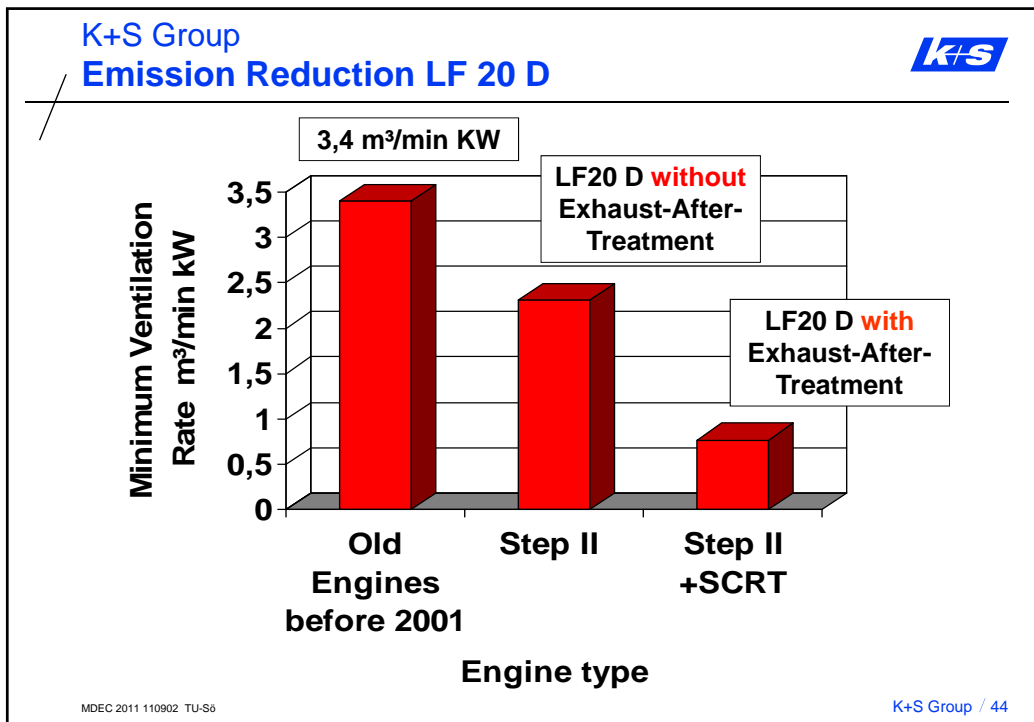

K+S Group  
**Air intake / Water Cooler (Step IIIB versus Step IV)** 

The engine company.

EAT Lösung 2015 CR  
 EU Stufe 3b / TIER 4 interim / EURO 5 vs. TIER 4 

**Engine Cooler**

Step IIIB 2011 → Step IV 2014

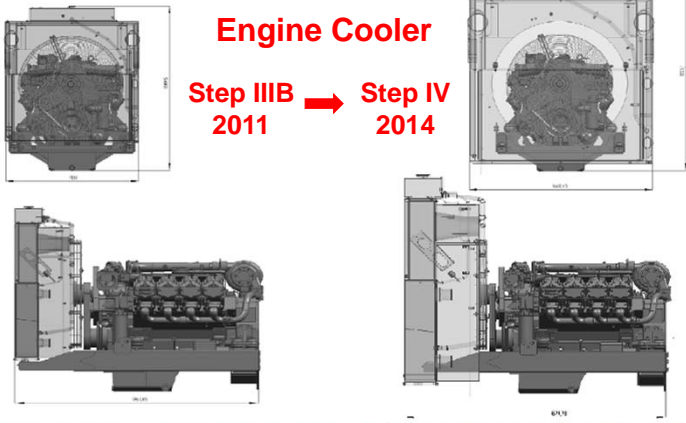

MDEC 2011 110902 TU-S6 K+S Group / 46

K+S Group  
**Challenges of the future** 

- Diesel engine and Exhaust Aftertreatment Systems become more and more complex ⇒ special requirements for service
- TLV's must be of profound justification to still allow mining
- Engine technologie Tier IV final in 2014 is in development!  
Space for the air intake / Water cooler ?
- Retrofit of older machines / engines is difficult due to required adaption process to actual load cycles
- System designs have to be improved with respect to the special mining conditions

MDEC 2011 110902 TU-S6 K+S Group / 47