

**U.S. Salt Mines
&
DPM Control Strategies
By:
E. Z. Manos**

Introduction

- ∄ Brief History of the Hutchinson & Detroit Salt Mines**
- ∄ Ventilation Systems**
- ∄ Baseline DPM Studies**
- ∄ Ventilation Modifications**
- ∄ Equipment**
- ∄ Use of Soy Fuel**
- ∄ Discussion of Results**

Hutchinson Salt Mine



History of the Hutchinson Mine

Hutchinson Salt Mine

- € Mining Depth is 645 feet
- € Carey Family Developed salt mine in 1922
- € Room & Pillar mining is Employed
- € Used Electric Equipment from 1922-1984. After 1984 diesel equipment was introduced.
- € 1000 tons per day single shift

Hutchinson Ventilation System

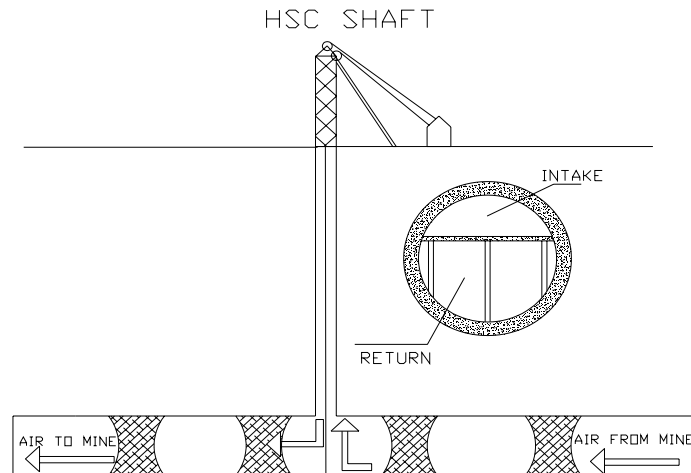

Hutchinson Salt Mine Main fan

- € 48 inch diameter Peabody Axial Vane
- € Frequency Controlled
- € Operates at 6.2 in of Total Pressure
- € Generates 75,000 cfm.
- € 150 Hp Motor

In June 2001, a joint MSHA/Industry protocol led to MSHA conducting baseline DPM studies of 31 Metal/Nonmetal underground mines.

Hutchinson Salt Mine

Baseline DPM Exposures

			TC	EC
Date	Location	Job	µg/m ³	µg/m ³
10/17/2001	UG	LHD Operator	330	271
10/17/2001	UG	LHD Operator	415	349
10/17/2001	UG	Laborer	22	22
10/17/2001	UG	Powder man	368	305
10/18/2001	UG	Crusher Operator	192	139
10/18/2001	UG	Cutting Mach Operator	402	345
10/18/2001	UG	Laborer	172	125
10/18/2001	UG	Hoist Operator	247	192
10/18/2001	UG	Mine Exhaust	968	872
10/18/2001	UG	LHD Operator	758	674

Ventilation Changes 2002 - 2003

- Ventilation curtains Moved Closer To Working Faces
- MSHA Particulate Sample November 26, 2002
 - Sample #1 Loader Operator 740 Micrograms Total Carbon
 - Powderman 471 Micrograms Total Carbon
- MSHA Particulate Sample April 15, 2003
 - Drill Operator 227 Micrograms Total carbon
 - Utilityman 204 Micrograms Total carbon
 - Cutter Operator 168 Micrograms Total carbon
 - Utilityman 76 Micrograms Total carbon

Summary of MSHA DPM Results Post Ventilation Modifications Hutchinson Salt Company

Date	Location	Job	Contam.	Conc'n	PEL
4/15/2003	UG	Drill Oper. Jumbo	TC	227	400
4/15/2003	UG	Utility Man	TC	204	400
4/15/2003	UG	Cutting Mach Oper.	TC	168	400
4/15/2003	UG	Utility Man	TC	76	400
4/15/2003	UG	Drill Oper. Rotary	TC/EC	229	400
4/15/2003	UG	Utility Man	TC/EC	201	400

Hutchinson Salt Mine

- € It was obvious that the results of the ventilation changes were not adequate to reach the ultimate goal of the 160 micro gram per cubic meter.
- € Hutchison then decided to try 100% soy fuel to reach the 160 limit.

B-100 Soy Fuel Facts

- 80% Less CO₂ In Emission
- 90% reduction In Un-burnt Hydro-Carbons
- 11% O₂ By Weight
- 80% Decrease BTUs
- Contains No Sulfur
- Flash Point 300 Degrees Fahrenheit
- 90% Reduction In Cancer Risk
- Bio-Degradable As Sugar

Hutchinson Salt Mine
Fuel Station



Hutchison Salt Mine
Equipment that uses Soy Fuel

Hutchinson Salt Mine
Tamrock 210
B-100 Fueled



Hutchinson Salt Mine
Maintenance Truck
350 Diesel Engine Equipped
B-100 Fueled



Hutchinson Salt Mine

420 CAT Scaler
B-100 Fueled



Hutchinson Salt Mine

Ford New Holland 1510
B-100 Fueled



Hutchinson Salt Mine

Powder Truck

B-100 Fueled



Hutchinson Salt Company

2003

B-100 Introduction

- June 17, 2003 Introduction of B-100
7 LHD One Month Pilot Program
- August 1, 2003
 - B-100 Utilized In All Diesel Equipment

Date	Location	Job	Cont.	Conc'n	PEL
11/18/2004	UG	Powder Gang	TC	97	400
11/18/2004	UG	Cutting Mach Oper.	TC	78	400
11/18/2004	UG	Drill Operator	TC	66	400
11/18/2004	UG	LHD	TC	66	400
11/18/2004	UG	Powder Gang	TC/EC	42	400
11/18/2004	UG	LHD	TC/EC	42	400
11/18/2004	UG	Drill Operator	TC/EC	34	400
11/18/2004	UG	Cutting Mach Oper.	TC/EC	32	400
3/2/2005	UG	Loader Operator	TC	90	400
3/2/2005	UG	Cutting Mach Oper.	TC	72	400
3/2/2005	UG	Drill Operator	TC	58	400
3/2/2005	UG	Laborer	TC	49	400

Detroit Salt Mine



History of the Detroit Mine

Detroit Salt Mine

- € **Underground Salt Mine in an Urban Area**
- € **1st Shaft was sunk in 1906, 2nd in 1926**
- € **1140ft (366m) in depth**
- € **Room and Pillar Mining Method**
- € **Ran Electric Equipment till 1950 and then a mix of diesel and electric to the present.**

Detroit Mine Operates Under A Two Shaft Ventilation System

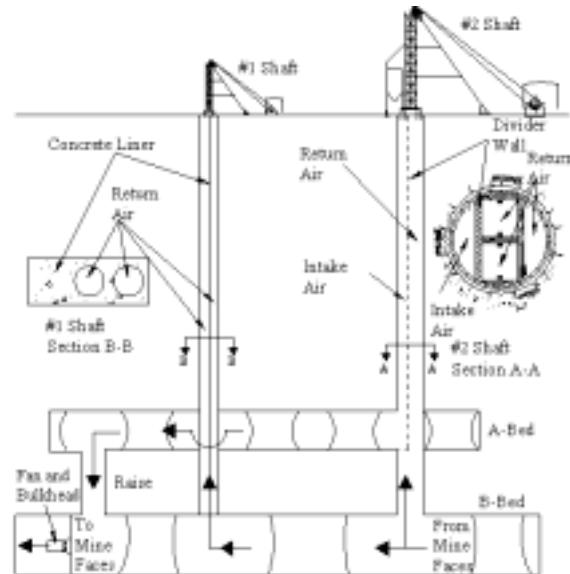

Detroit Salt Mine Main fan

- € Jeffery Model 8HU-60
- € Operates at 7.1 in of Total Pressure
- € Generates 127,000 cfm.
- € 200 Hp Motor



Detroit Salt Company

In house Baseline DPM exposure study

			TC	EC
Date	Location	Job	$\mu\text{g}/\text{m}^3$	$\mu\text{g}/\text{m}^3$
12/4/2001	UG	Powder Gang	719	366
12/4/2001	UG	Powder Gang	656	329
12/4/2001	UG	Air Intake	72	42
12/4/2001	UG	Wagon	1024	458
12/4/2001	UG	Cross Out	435	305
12/4/2001	UG	Cross Out	466	305
12/4/2001	UG	Wagon	926	458
12/4/2001	UG	Wagon	803	383
12/4/2001	UG	Wagon	708	383
12/4/2001	UG	Cross Out	383	283

Detroit Salt Mine Ventilation Changes

- ∅ Re-Constructed air walls in intake air coarse.
- ∅ Constructed leak resistant pressure walls on the pressure side of the fan.
- ∅ Removed a high velocity shock loss from the #2 air intake shaft plenum.

Detroit Salt Mine
Tensor/shot-creted walls in fresh air system



Detroit Salt Mine
ABC Brattice Wall in fresh air system



Detroit Salt Mine
High Pressure air wall during construction



Detroit Salt Mine
Completed High Pressure air wall with shot-crete



Removal of Intake Shaft shock loss



MSHA DPM Results Post Ventilation Modifications Detroit Salt Company

Date	Location	Job	Cont.	Conc'n	PEL
12/17/2003	UG	Powder Gang	TC	446	400
12/17/2003	UG	Drill Operator	TC	445	400
12/17/2003	UG	Loader Operator	TC	241	400
12/17/2003	UG	Loader Operator	TC	201	400
12/17/2003	UG	Powder Gang	TC	510	400
12/17/2003	UG	Drill Operator	TC	497	400
12/17/2003	UG	Loader Operator	TC	273	400
12/17/2003	UG	Loader Operator	TC	221	400
3/2/2004	UG	Powder Gang	TC	407	400
3/2/2004	UG	Drill Operator	TC	366	400
3/2/2004	UG	Loader Operator	TC	289	400
3/2/2004	UG	Cutting Mach Oper.	TC/EC	259	400
3/2/2004	UG	Powder Gang	TC/EC	469	400
3/2/2004	UG	Drill Operator	TC/EC	431	400
3/2/2004	UG	Drill Operator	TC/EC	276	400
3/2/2004	UG	Cutting Mach Oper.	TC/EC	105	400

The Detroit Salt Mine decided to run a trial period using 100% Soy Fuel in May of 2004 in it's underground equipment.

980G Caterpillar Front End Loader
310 Hp



Cannon Jumbo Drill 200 hp Cat engine



Getman Roof Scaler 113 Hp Deutz Electronic Motor



Getman Powder Machine 113 Hp Electronic Deutz Motor



Detroit Salt Company MSHA DPM Sample Results Using 99% Soy Fuel

Date	Location	Job	Contam.	Conc'n	PEL
8/10/2005	UG	Cutting Mach Oper.	TC	142	308
8/10/2005	UG	Powder Gang	TC	112	308
8/10/2005	UG	Loader Operator	TC	60	308
12/8/2004	UG	Powder Gang	TC	159	400
12/8/2004	UG	Powder Gang	TC	136	400
12/8/2004	UG	Drill Operator	TC	71	400
12/8/2004	UG	Loader Operator	TC/EC	147	400
12/8/2004	UG	Loader Operator	TC/EC	114	400
12/8/2004	UG	Powder Gang	TC/EC	68	400

Discussion of Results

From use of B-100 Soy Fuel

- Using a 99% to 100% clearly reduced the DPM Exposures values in the Hutchinson and Detroit Salt Mines by as much as 80%.
- Exhaust from diesel engines is clear, black soot problems are eliminated.
- The 99-100% fuel acts as a detergent therefore fuel filters will have to be changed until the system is clean or start with clean tanks on the machine and clean fuel storage tanks.
- Older or cracked rubber hoses will need to be replaced because this fuel will leak through them.
- The Soy fuel will eat paint when spilled.
- Current supply is subsidized by US Government and is limited.

Conclusions

- € The use of Soy as a fuel source in diesel equipment in these two underground mines has dramatically lowered DPM sample values.
- € The use of Soy Fuel in 100% - 99% by volume has shown no ill effects to engine performance, horse power, cooling, this up to 325 horse power engines.

Acknowledgements

€ I would like to express, gratitude to Hutchin's and Detroit Salt Company's management and staff for allowing this opportunity to present the findings from this mine ventilation study.